

Version
02.00September
2003

R&S® UMTS PN Scanner for Expert System R&S® Romes-US1

Drive test equipment for network planning, design, installation, optimization, quality assurance and service

- ◆ Easy, time-saving and high-precision UMTS coverage measurements and network optimization
- ◆ Extremely fast measurements in high-speed mode (10 measurements/s)
- ◆ Extreme sensitivity up to -127 dBm in high-dynamic mode
- ◆ 2×2500 dynamic rake fingers for detecting UMTS signals
- ◆ High-speed synchronization to PN codes (10 ms for 5 pilots)
- ◆ Standard processor platform, PCs or notebooks with Windows 2000/XP can be used
- ◆ Measurement of multipath propagation (CIR view)
- ◆ Multichannel measurements (up to 12 channels per test drive)
- ◆ Display of UMTS frequency band and uplink and downlink spectrum with a dynamic range of 70 dB
- ◆ Spectrum history display for detecting external interferers and fading effects
- ◆ Automatic best server display mode (Top 1 to Top 32)
- ◆ Analysis of pilot pollution
- ◆ Power measurements in P-SCH (primary) and S-SCH (secondary synchronization channel)
- ◆ Measurement of relative frequency error of base stations
- ◆ Root mean square (RMS) delay spread referenced to a chip
- ◆ Measurement of time drift of base stations referenced to GPS time
- ◆ Measurement of Doppler frequency of individual paths
- ◆ GPS system with mapped measured values

PN scanners reduce problems in UMTS networks

Pseudo random noise code scanners (PN scanners) are used to closely analyze the reception conditions in a 3GPP network. By means of the measured data, network operators can quickly detect errors in planning and setup, eliminate them and also refine their planning tools. Pilot pollution can be caused by a number of factors, e.g. uneven terrain or bridges and overpasses that are covered by too many transmitter stations at the same time and on the same RF channel. Despite high field strength, connection is poor because of co-channel interference. In these situations, UMTS is more tolerant than GSM – interference does not lead to disconnection, only to a reduced data rate. This, however, causes additional load on the radio channel. To maintain the minimum transmission rate, transmit power is increased and handovers are made to the base stations with the best reception in this area. Since the desired characteristic, best server, is only of short duration with pilot pollution, handovers that tie up further precious channel resources occur frequently. By adjusting cell size parameters or aligning a few antennas, pilot pollution can often be eliminated by means of the measurement data from PN scanners, thus enabling better use of the limited frequency band and increasing the average data rate.

Advantages of the R&S UMTS PN Scanner Expert system

- ◆ Universal RF frontend, spectrum analyzer or test receiver
- ◆ No authorization, e.g. by SIM card, required for measuring
- ◆ Versatile indoor and outdoor applications
- ◆ Future-proof owing to modular R&S ROMES control software
- ◆ Informative displays for online analysis such as X/Y diagram, table, statistics, map display, plus specific UMTS displays

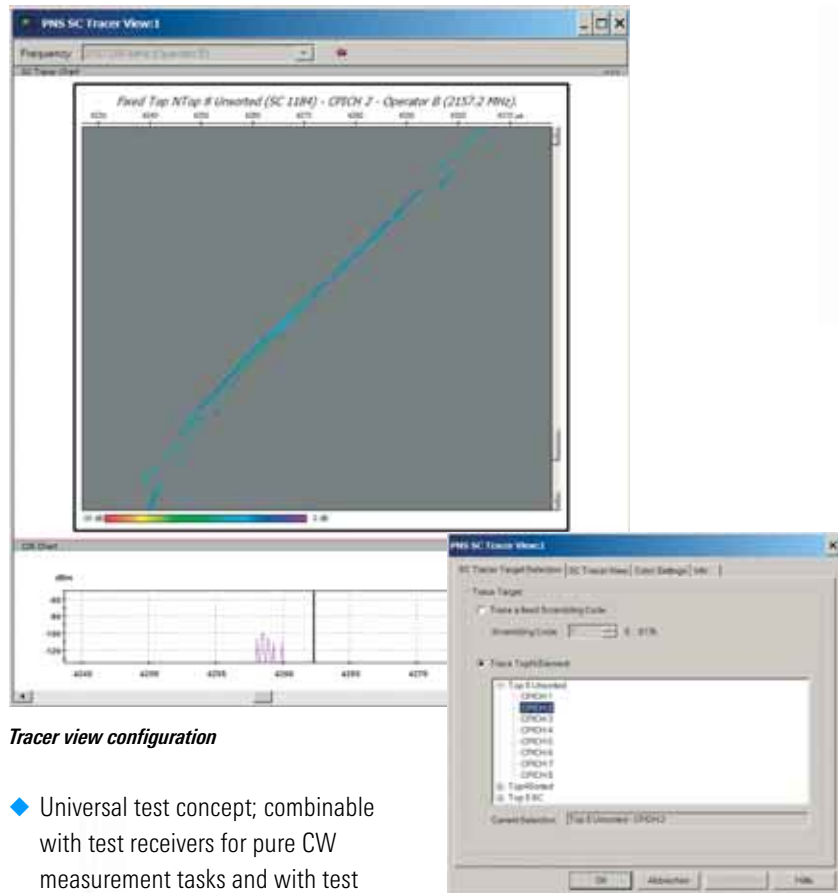

Tracer view configuration

- ◆ Universal test concept; combinable with test receivers for pure CW measurement tasks and with test mobiles for CDMA, GSM/GPRS
- ◆ Post Processing Tool R&S RODAS for processing individual, regional or nationwide measurement data from UMTS or other technologies

Rohde&Schwarz has developed this instrument to achieve highest quality and customer satisfaction. The minimum necessary components are

- ◆ Test Receiver R&S ESPI or Spectrum Analyzer R&S FSP/FSU
- ◆ R&S ROMES network optimization software with R&S UMTS PN Scanner module
- ◆ GPS with PPS pulse and/or synchronization unit for triggering
- ◆ PC or notebook

The principle behind this analyzer is different from that of all other currently available products. Ordinary PN scanners use the standard technology of mobile telephones by means of regular, hardware-based rake receivers. To fulfill the

real requirements for interference analysis in UMTS, Rohde&Schwarz has replaced this principle by developing dynamic rake receivers. These dynamic rake receivers are capable of tracing up to 5000 different signal propagation paths leading to max. 2500 node B simultaneously, while static rake receivers allow the tracing only of 4 or 8 paths.

With this technology, the R&S UMTS PN Scanner can synchronize on UMTS base stations with unprecedented speed, accuracy and dynamic range. Future development will include a 3GPP telephone (commercial and with trace function) to add smart control. The R&S UMTS PN Scanner is part of the extensive R&S ROMES software platform, which supports simultaneous measurement and analysis within different wireless network technologies. Measurement data is stored together with positioning and timing information, for replay or detailed analysis and subsequent processing.

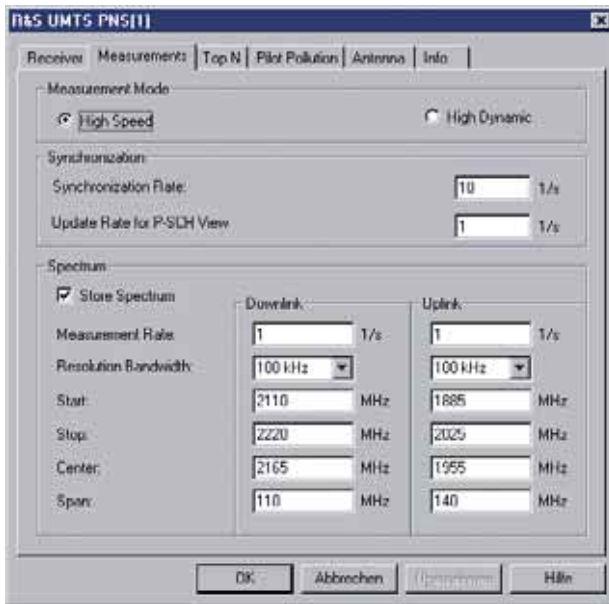

UMTS measurement and spectrum settings

Spectrum display of UMTS band – uplink and downlink

SC (scrambling code) trace view

To trace certain characteristics in the reception of one scrambling code from one node B, the SC trace view has been implemented in the R&S UMTS PN Scanner. This view shows the channel impulse response (CIR) on one scrambling code, in a 2D chart and in a waterfall diagram, for analysis of propagation channels varying over time. Particularly the waterfall diagram gives insight into all reflections and interferers for a node B. It is possible to open multiple scrambling code trace views, as many as are necessary for a test drive. Otherwise one of the Top N scrambling codes of the CPICH view will be displayed. In addition, the tracer view can be configured with different colours to customize the displays as needed.

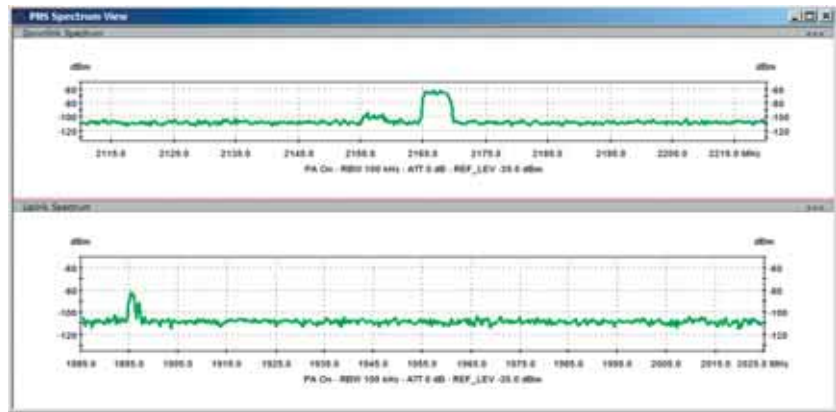

RF spectrum view

The display of RF spectra provides important information about signal characteristics, particularly fading effects and interferers on co- or adjacent channels. The R&S UMTS PN Scanner uses the spectrum analyzer functions of the R&S ESPI or R&S FSP/FSU to make different types of spectra available. It is possible to fully configure two independent spectrum displays. The spectra can, for example, show the uplink and downlink channels, or the complete UMTS DL band and one uplink channel. The update rates can be set by the operator, independent from each other.

Spectrum history view

For even better analysis, the spectrum history view is available. It shows more than just the current spectrum. A coloured waterfall diagram makes it easy to observe the spectrum development during the drive test. Fading effects on different channels as well as specific incidents can be seen. One extremely important aspect shown on this display is the detection of external (i.e. non-UMTS) interference, which can be determined easily. Like all other displays the spectrum history display can be configured, separately for uplink and downlink.

Pilot view

The pilot view shows all pilots found at the measurement point together with a history of previously measured pilots for some time. The view has two display modes. The Min-Max-Average-Current mode shows the minimum, the maximum, the average and the current value of the RSCP of the scrambling code. The Bar mode shows the RSCP in the standard form.

Top N view

For various optimization and verification measurements, a configurable display that automatically sorts the best values is very useful. The Top N view has these capabilities and permits the selection and display of the best server(s). See also the configuration settings for Top N views.

Standard views

In addition to the special R&S UMTS PN Scanner views, the measured data (E_c/I_0 , SIR, RSCP, ISCP and power) can be displayed in the R&S ROMES standard views, e.g. alphanumeric view, 2D chart view and route track view.

Frequency selection concept

Since the system is able to analyze UMTS signals in different frequency bands within one measurement section, all UMTS network information views are with multiple views headlines and synchronized with one frequency selection bar. Each (multiple) view may be opened for different instances, and each instance may be configured separately. A frequency selection bar is available for simultaneously switching all views with the same instance number to a selected frequency. It is possible to display measurement results of different frequency bands within multiple instances of UMTS network information views in parallel. By means of a single mouse click, the user can also open only one instance of different views and examine all views with reference to one measured frequency band.

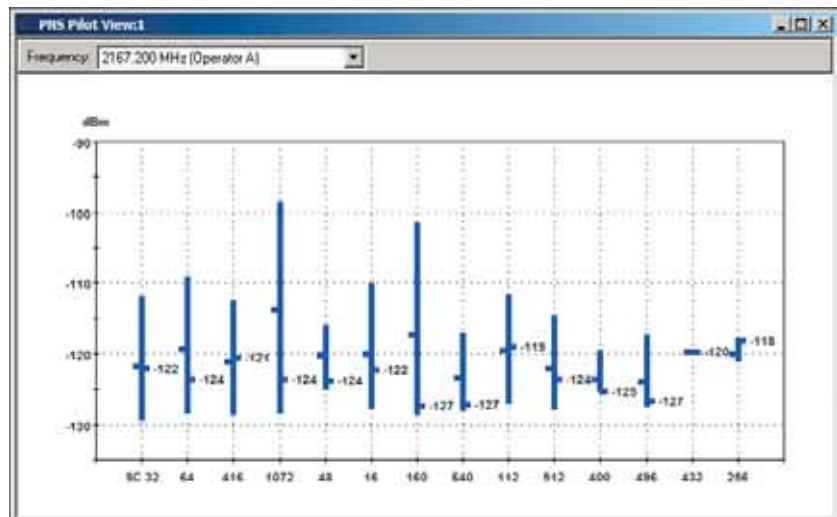

Pilot view (average, min, max, current)



2D chart view for RSCP

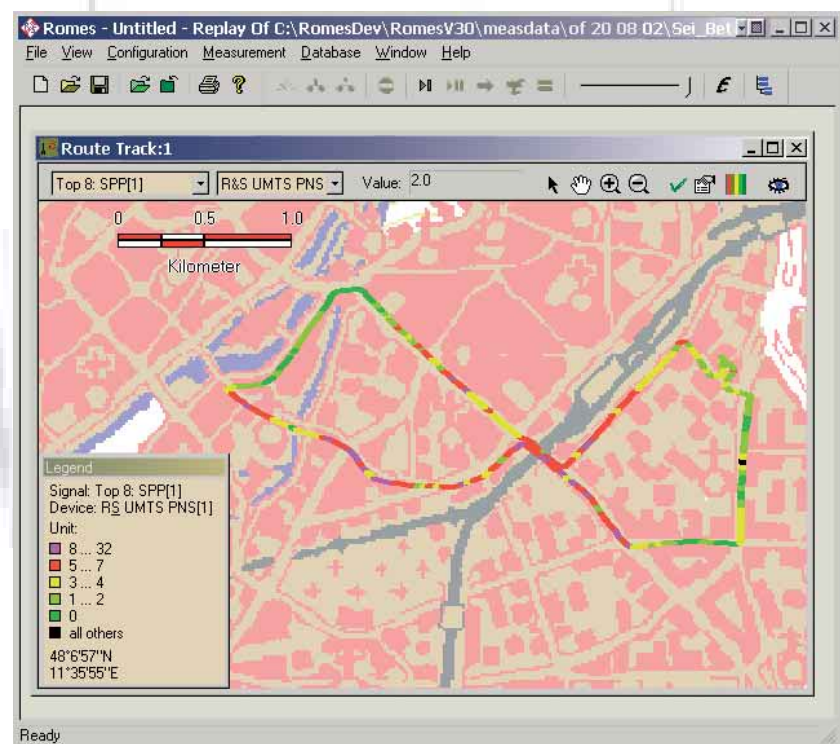

Route track module with GPS status info display

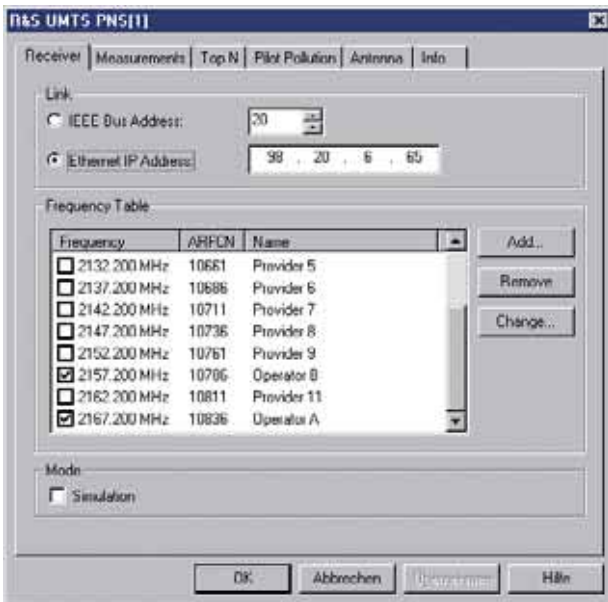

UMTS receiver settings for R&S ESPI or R&S FSP/FSU

When measurement results relating to different frequencies can be viewed such as in the spectrum, Top N or trace view, the frequency bar is switched to either "inactive" or "not implemented".

UMTS receiver settings

Only a few receiver settings need to be require the mere setting of

- ◆ Type of receiver (Test Receiver R&S ESPI or Spectrum Analyzers R&S FSP/FSU)
- ◆ Type of connection (LAN or IEEE 488.2)
- ◆ Selected frequency bands and provider name
- ◆ New frequency bands and provider names, if needed
- ◆ Simulation mode on/off



Top N view, E_c/I_0 sorted

All other relevant parameters will automatically be set to their optimum values

- ◆ Minimum measurement interval in slots
- ◆ Number of slots used
- ◆ Number of rakes
- ◆ Total dynamic range
- ◆ Maximum peak dynamic range
- ◆ Total dynamic range for code
- ◆ Maximum peak dynamic range for code
- ◆ Sample distance for spectrum
- ◆ Number of samples for spectrum
- ◆ Overlap of samples for spectrum



Top N view, RSCP sorted

Software user interface

Modular concept

R&S ROMES is based on a modular system concept, allowing any type of data to be collected and analyzed. Any sensor (e.g. test receiver, test mobile or GPS receiver) capable of result transfer to a PC or notebook can be integrated into the system family. This opens a wide range of uses, from measurements in mobile radio to almost any kind of measurement application. The modular concept enables the implementation of very small systems and high-performance systems alike. And it makes the software future-proof, as it can easily be extended to accommodate upcoming technologies. The R&S UMTS PN Scanner is embedded in the modular R&S ROMES network optimization software. It consists of a dedicated driver which has to be installed together with the base software platform (see data sheet R&S ROMES, PD 0757.6679). The core acts as a shunting station. It transfers data from the external hardware via the driver to the result file and the displays. Two main types of display are supported: the general view e.g. 2D chart,

alphanumeric or GIS view, and the technically specific view, e.g. GSM measurement report, R&S UMTS PN Scanner view, etc. Data post-processing with external software, e.g. Excel is also possible. A convenient, user-definable export function and numerous specific export functions are available. The system can easily be upgraded to any new hardware that is attached merely by installing a new driver.

Top N configuration

All Top N views are fully user-configurable:

- ◆ User-specific name of this Top N
- ◆ Number of CPICHs
- ◆ Frequencies: only CPICHs detected on the selected frequency are taken into account
- ◆ Interval of observation for rank decision
- ◆ Calculation mode: peak or average
- ◆ Hysteresis for rank changes



UMTS Top N property settings

All configured Top N views are available as parameters for all basic views, e.g. 2D chart view, alphanumeric view or route track view. This allows the best server for a configured Top N to be followed – on the map or to see its graph in the 2D chart view.

Pilot pollution configuration

The R&S UMTS PN Scanner automatically calculates the pilot pollution for the current server. To provide a helpful and quick overview of the quality of the coverage, two parameters were designed. The hard pilot pollution (HPP) counts all measured

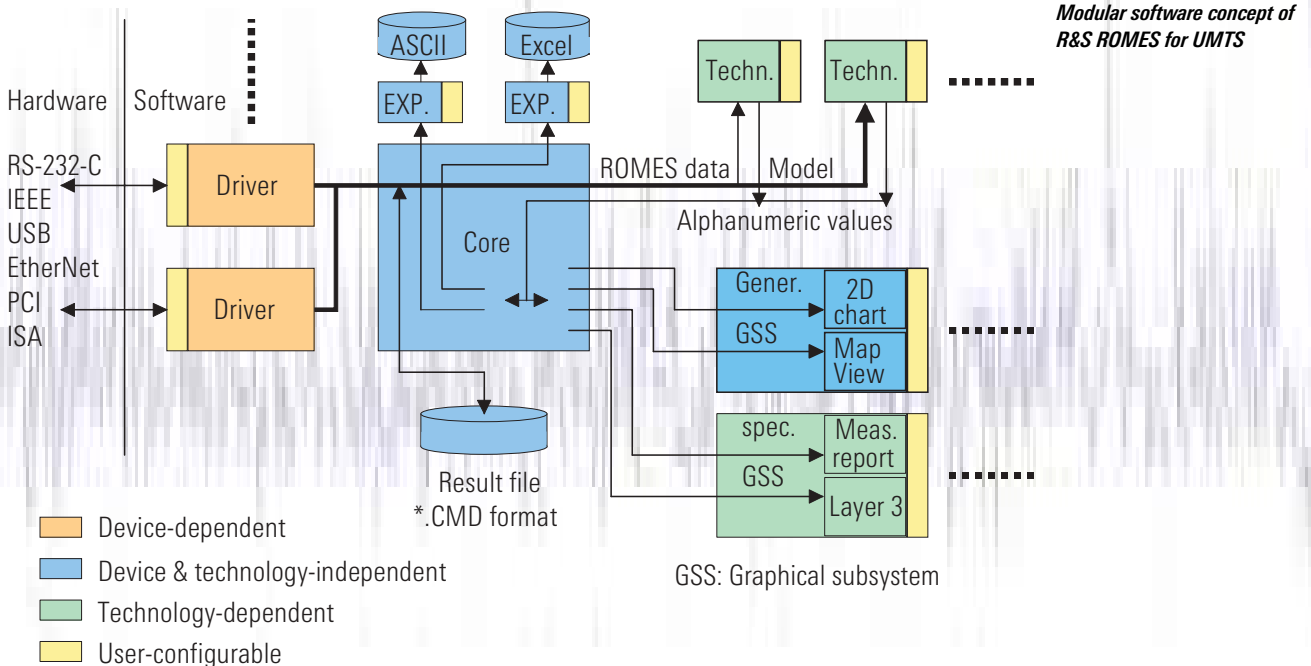

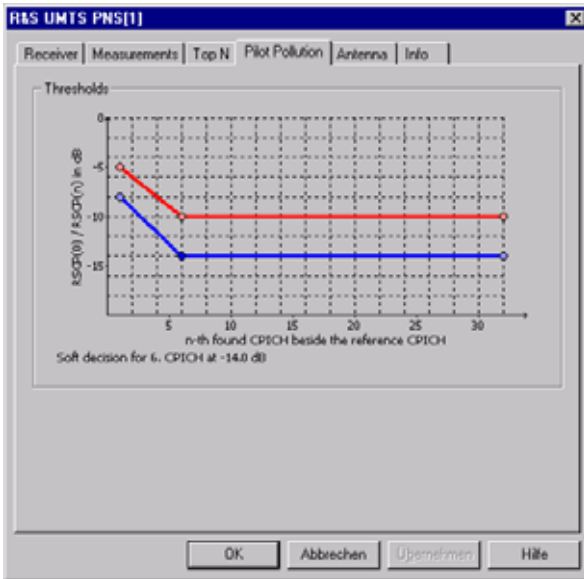

Pilot pollution info settings

PN scanner configuration and applications

The R&S UMTS PN Scanner can be configured either as a cost-effective version with a notebook or as a high-performance solution. The preferred system solution depends on the field of application. The notebook version is for flexible applications, e.g. when used in different vehicles or indoors. All system components can be used as standalone devices; magnetic antennas are employed, and power is supplied from the test vehicle. The high-performance system solution is designed as a turnkey solution for installation in a test vehicle. The sturdy and robust construction ensures reliable tests and measurements even under difficult environmental conditions. The system can be configured either as a pure PN scanner or as a CW (level measurement, only R&S ESPI) and PN scanner. The R&S FSP/ESPI that are used as an RF frontend and spectrum analyzer in this application are top-quality, state-of-the-art products from the Rohde&Schwarz family of test instruments.

CPICHs with an RSCP higher than the red graph. The soft pilot pollution (SPP) counts all measured CPICHs, with an RSCP is higher than the red graph, and all that have an RSCP between the blue and red graph with a value between 0 and 1. The red and blue graphs are user-configurable and can be adapted to specific

conditions or measurement goals. There is no difference between using E_c/I_0 or RSCP for to calculate the pilot pollution, because $[E_c(SC 1)/I_0]/[E_c(SC 2)/I_0]$ is identical to $[RSCP(SC 1)]/[RSCP(SC 2)]$ for one single measurement, where E_c is directly proportional to RSCP.

System configuration of the R&S UMTS PN Scanner



Future development

Rohde&Schwarz ensures a long product life cycle. Part of this long-term planning is the continuous development and enhancement of existing products and platforms, but another part is development of new products that will be added to the R&S ROMES product family of network optimization systems. Compared to other available products, the R&S UMTS PN Scanner has the exceptional advantage that it is developed as an R&S ROMES software option that runs on regular PCs. Minor modifications or major add-ons are developed in short cycles; they require a mere software update or upgrade to the existing systems. No hardware changes are necessary.

The R&S ESPI and the R&S FSP/FSU are being used as a frontend. For the future, new and more compact receivers that fulfill the necessary requirements for high-quality measurements in UMTS and other bands can easily be integrated into the system concept. The road map for the R&S UMTS PN Scanner foresees, among numerous other developments, the integration of UMTS test mobiles. This will allow the signalling capabilities of the test mobile to be combined with the RF analysis capabilities of the PN scanner. There will be a tracking mode in which the serving cells in UMTS will automatically be set for the analyzer (all RF channels and scrambling codes), provided the UMTS mobile phone delivers this information.

New features

- ◆ Use of UMTS base station lists with position determination for unknown base stations
- ◆ End-to-end data and testing (QoS) with commercial UMTS mobile phones
- ◆ Evaluation software module UMTS for R&S RODAS (successor of R&S ROSEVAL)



Specifications

RF frontend	
Frequency range	9 kHz to 3 GHz (7 GHz with R&S ESPI7)
Frequency accuracy	±1 ppm ±0.01 ppm with OCXO Option R&S FSP-B4
OCXO aging	±0.1 ppm
Frequency resolution	0.1 Hz
IF bandwidth	10 Hz to 10 MHz (steps 10, 3) Multiple special filters from 100 Hz to 8 MHz, specifically DAB/DVB, cdmaOne, TETRA, IS-136, WCDMA
RF input	50 Ω impedance, N connector
Trigger input	BNC connector
RF input range	-150 dBm to +30 dBm (in UMTS band)
Level accuracy	<1.5 dB (receiver mode) <0.5 dB (analyzer mode)
Noise figure	21.5 dB (12 dB with preamplifier option)
1 dB compression point	0 dBm nominal
Adjacent channel desensitization	Depends on resolution bandwidth (RBW)
IP3	>2 dBm, typ. 5 dBm
UMTS interference analyzer	
Time accuracy	±1 ppm ±0.01 ppm with OCXO Option R&S FSP-B4 infinite with GPS PPS
Sampling rate	1/2/5/10 Hz
Synchronization acquisition time	24 ms per pilot
Synchronization level E_c/I_0	<-14.5 dB (high-speed mode) <-25 dB (high-dynamic mode)
Number of rake receivers	2 × 2500
Power measurement with R&S ESPI	-119 dBm to +10 dBm (high-speed mode) -127 dBm to +10 dBm (high-dynamic mode)
Power measurement with R&S FSP/FSU	-110 dBm to +10 dBm (high-speed mode) -118 dBm to +10 dBm (high-dynamic mode)
Level accuracy	<1.5 dB (E_c/I_0) <1 dB (RSCP)
Adjacent channel rejection	>65 dB, typ. >70 dB
Base station measurement	max. 2500 base stations (node B) simultaneously
Spectrum monitor function	2 spectra (uplink and downlink, user-configurable)
Display resolution	max. 1600 × 1200, depending on monitor
Parameter display	
UMTS	Spectrum view, user-configurable for 2 spectra (e.g. uplink and downlink, downlink and UMTS band) Spectrum history view (multiple) CPICH view (multiple) P-SCH view (multiple) Scrambling code trace view (multiple) Channel impulse response view (multiple) Pilot view (multiple) Top N view (multiple)

General	General status view Event/alarm view 2D chart view (multiple) Alphanumeric view (multiple) Parameter statistics view (multiple) Route track view for realtime map display (multiple) GPS info view Indoor view for realtime indoor map display
---------	---

Data storage in R&S ROMES

Full storage with spectra	
High sensitivity	less than 200 Mbyte per hour
High speed	less than 2000 Mbyte per hour

Normal storage (reduced spectrum and P-SCH at 1 Hz): 60 Mbyte per hour, zipped approx. 50 Mbyte

Minimum storage (without spectrum and P-SCH): 8 Mbyte per hour, zipped approx. 2 Mbyte

Measured parameters

General	RSSI of received channel E_c , E_c/I_0 , SIR, RSCP, ISCP, total power
Top N	E_c/I_0 (peak of average for observation interval) RSCP
P-SCH/S-SCH	Graphical display of correlation result Relative power of detected peaks (in dB) Time delay of detected peaks (in ms)
P-CPICH	Scrambling code (up to 512, hexadecimal) Total power of CPICH (in dBm)

Parameters for every scrambling code

Result	Description	Specification
E_c/I_0	Received energy per chip divided by the power density in the band	TS 25.215; 5.1.6
SIR	Signal to interference ratio	TS 25.215; 5.1.3
RSCP	Received signal code power	TS 25.215; 5.1.3
ISCP	Interference signal code power	TS 25.215; 5.1.3

Table 1: Measured parameters of CPICH per scrambling code

Parameters per identified peak for every scrambling code

Result	Description
Power	Power of identified peak
Time	Relative time of arrival Absolute timing against GPS clock

Table 2: Measured parameters of CPICH per identified peak for every scrambling code

Spectrum	Spectrum, full or partial, of UMTS downlink and/or uplink band Spectrum history
Sampling rates	The sampling rates depend on three aspects: Required measurements Number of node B and reflections in the air Performance of the controller (PC)

The following table shows the system's update rates in high-speed mode, based on measurements with the Process Controller R&S TSPC2 (2 × Pentium III 1 GHz). The measurements were performed in July 2002 with R&S ROMES Version 3.21 and 8 scrambling codes on one UARFCN:

Update rate in measurements/s	10	5	2	1
Spectrum uplink/downlink	✓	✓	✓	✓ refresh adjustable
Spectrum history	✓	✓	✓	✓ refresh adjustable
Top N		✓	✓	✓
P-SCH	✓	✓	✓	✓ refresh adjustable
P-CPICH	✓	✓	✓	✓
Peaks	✓	✓	✓	✓
# node B	30	30	30	30
Update [s]	0.1	0.2	0.5	1.0

Update rates in high-speed mode

The update rate in high-dynamic mode is approx. 1.0 s.

Dynamic range and sensitivity

The sensitivity of the R&S UMTS PN Scanner for the trace of E_c/I_0 and RSCP can reasonably be given only by probability. The diagrams below show the likelihood of detecting a pilot (per sample) for high-speed mode and high-dynamic mode. As up to 10 samples/s are taken in high-speed mode, a probability of 10% still delivers approximately one valid value per second (E_c/I_0 and RSCP) for the specified minimum sensitivity.

According to the above tables, CPICHs will analyzed with reasonable success up to the following value:

Mode		Dynamic range per sample	Sensitivity of R&S ESPI (R&S FSP/FSU with R&S FSP-B9)	Sensitivity of R&S FSP/FSU without R&S FSP-B9
High-speed	RSCP	20 dB (-119/-110 dBm to -10 dBm)	-119 dBm	-110 dBm
High-dynamic	RSCP	29 dB (-127/-115 dBm to 0 dBm)	-127 dBm	-115 dBm

Typical sensitivity and dynamic ranges

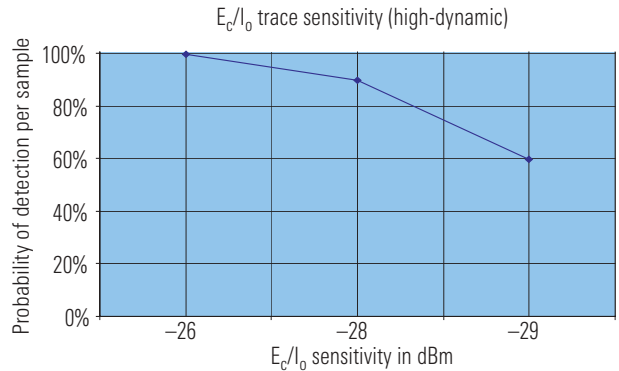
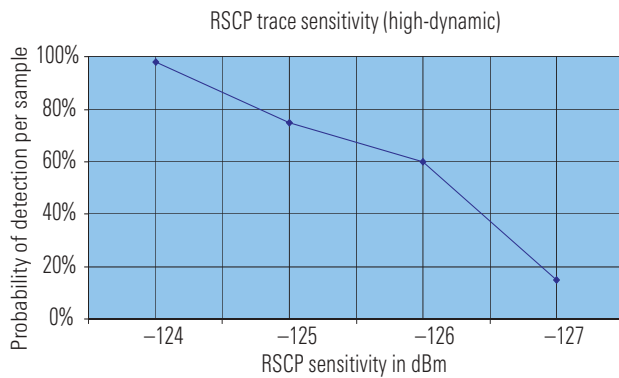
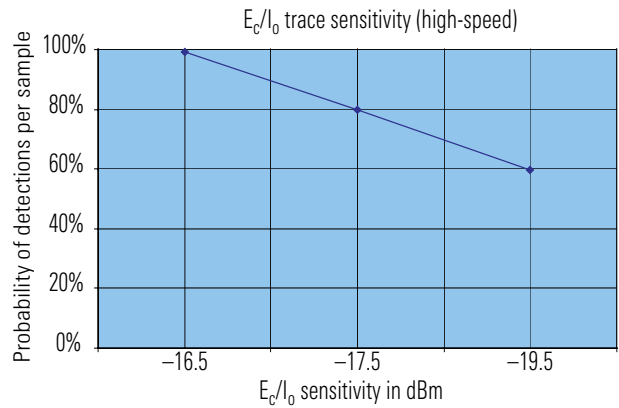
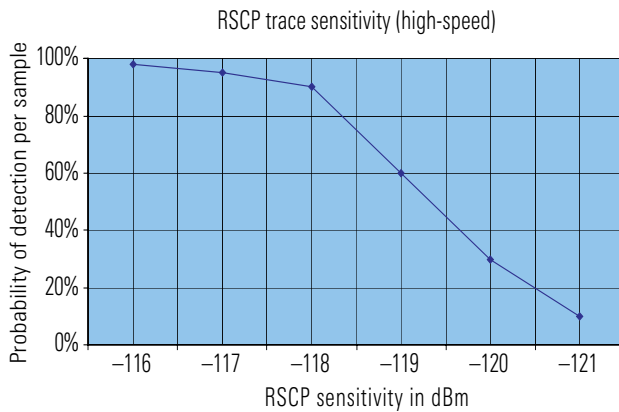

Ordering information

Laptop configuration

Designation	Type	Order No.
Tablet PC	R&S TS-TB1	1070.5872.13
IEC625/IEEE488 PCMCIA Type II Card	R&S TSNB-IEC1	1042.0970.02
GPS Navigation System	R&S TS95GPS	1090.8348.02
EMI Test Receiver ¹⁾	R&S ESPI3	1142.8007.03
Preselector for R&S ESPI ²⁾	R&S ESPI-B2	1129.7498.02
LAN Interface 10/100 BaseT for R&S FSP/R&S ESPI	R&S FSP-B16	1129.8042.02
OCXO 10 MHz for R&S FSP/ESPI	R&S FSP-B4	1129.6740.02
Power Supply 12 V DC for R&S FSP/ESPI	R&S FSP-B30	1155.1158.02
Documentation of Calibration Values	R&S DCV-2	0240.2193.09
Trigger for Coverage Measurements with R&S FSP/ESPI3	R&S ESPI-K50	1106.4386.02
CW Driver for R&S ESPI	R&S ROMES-AS5	1143.8198.02
Synchronization Unit for R&S TS5K1C	R&S TS-95SYN	1114.4817.02
R&S ROMES3 R&S UMTS PN Scanner Software Driver	R&S ROMES-US1	1156.2858.02
Basic Measurement Software R&S ROMES3 without Hardlock	R&S ROMES	1143.7991.02
Evaluation Software R&S RODAS Lite+	R&S RODAS	1117.5495.12
UMTS Module for R&S RODAS	R&S RODAS-U	1117.5495.20

¹⁾ R&S FSP can replace R&S ESPI for PN scan only; no CW uses.

²⁾ Factory installation only for R&S ESPI.

UMTS high-performance system

Designation	Type	Order No.
System controller, LC display and interfaces		
System Process Controller	R&S TSPC2	1161.4310.02
High-Performance GPIB Interface	R&S TS-IEC1	1042.1276.02
RS-232-C Interface ¹⁾	R&S TSPC-SER8	1029.5871.02
15.1" TFT Display	R&S TSPC-LCD1	1064.5800.02
19" Rack for R&S TS9955 (15 HU)	R&S TS955RA	1053.5590.02
Measurement Cable Set for R&S TS9955	R&S TS955KS	1042.9631.02
Hardware Integration into Rack for R&S TS9955	R&S TS955HI	1053.5603.02
All other options as in the laptop configuration		

¹⁾ For System Process Controller R&S TSPC2.

More information at
www.rohde-schwarz.com
(search term: UMTS PN Scanner, Romes-US1)



ROHDE & SCHWARZ

Rohde & Schwarz GmbH & Co. KG · Mühlendorfstraße 15 · 81671 München · Germany · P.O.B. 80 14 69 · 81614 München · Germany · Telephone +49 89 4129-0
www.rohde-schwarz.com · Customer Support: Telephone +49 1805124242, Fax +49 89 4129-13777, E-mail: CustomerSupport@rohde-schwarz.com

R&S® is a registered trademark of Rohde & Schwarz GmbH & Co. KG · Trade names are trademarks of the owners
PD 0758.0045.32 · R&S® UMTS PN Scanner for Expert System R&S® Romes-US1 · Version 02.00 · September 2003 · Data without tolerance limits is not binding · Subject to change

Printed in Germany (Pe as)